

GOLDLITE SUPPLIES

HOLIDAY ASSIGNMENTS

Contact us on 0724351706

ALL SUBJECTS COMBINED

GRADE 6 2026

NAME: _____ ASSESSMENT NUMBER: _____

SCHOOL: _____ DATE: _____

SOCIAL STUDIES

TIME: 1 HOUR 40 MINUTES

Exceeding Expectation	Meeting Expectation	Approaching Expectation	Below Expectation	Total Score (%)

Answer all questions.

Use the sketch map of Upendo Area to answer Questions 1–5.

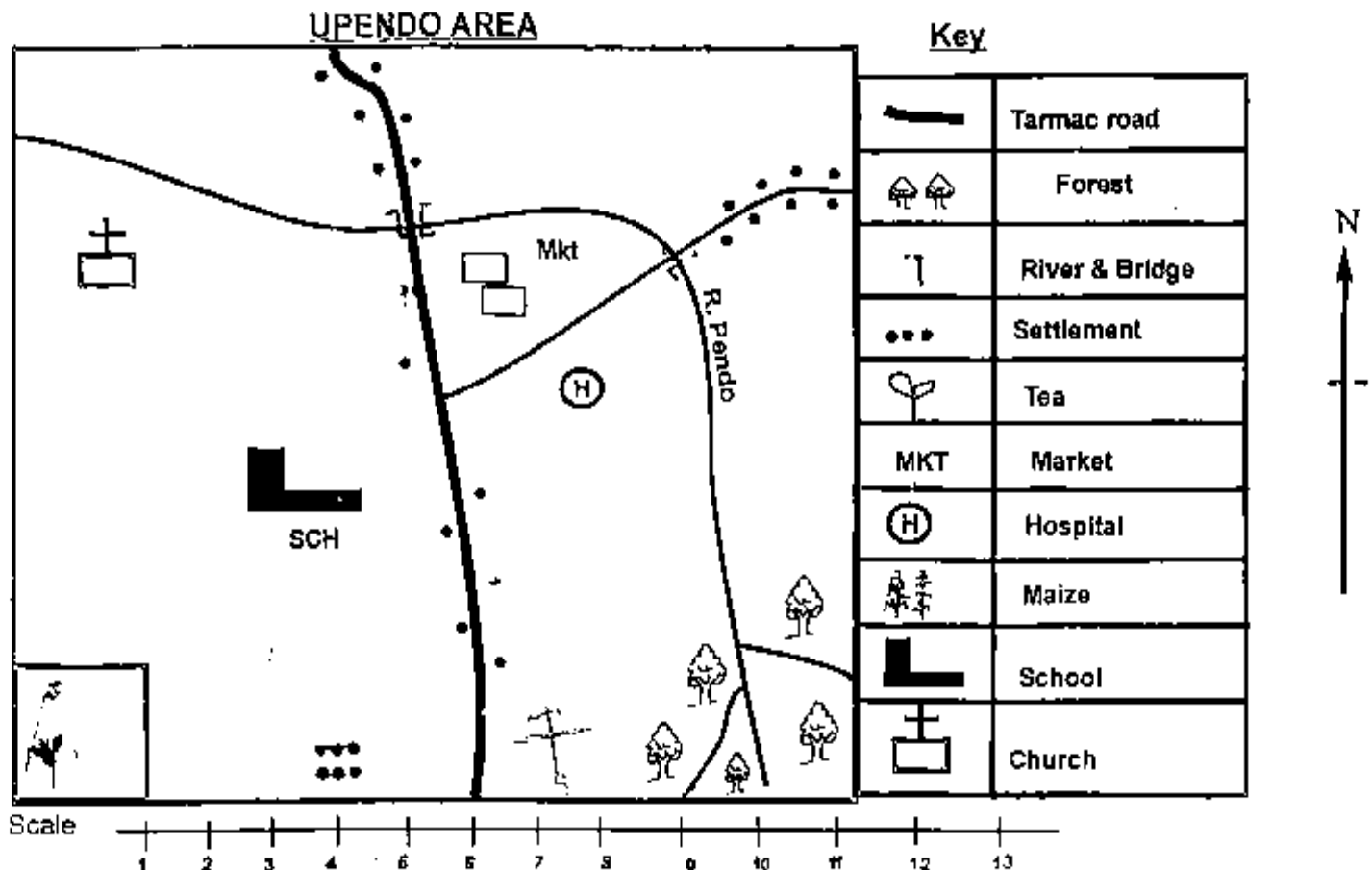

1. Which is the main cash crop grown in Upendo area?
A. Tea B. Maize C. Coffee D. Sisal
2. River Pendo flows from:
A. North West B. East
C. South East D. South
3. Identify the settlement pattern shown in Upendo area.
A. Dense B. Sparse C. Clustered D. Linear
4. What is the direction of the maize farm from the forest?
A. North B. West C. East D. South
5. The people of Upendo area are likely to be:
A. Traditionalists B. Christians
C. Muslims D. Pagans
6. Which of the following groups consists of Central Bantus only?
A. Agikuyu, Ameru, Akamba
B. Abaluhya, Abakuria, Abasuba
C. Ameru, Kuria, Pokomo
D. Mijikenda, Abagusii, Aembu
7. Which group shows drainage features only?
A. Mountains, lakes, hills
B. Hills, valleys, mountains
C. Oceans, lakes, rivers
D. Plains, plateaus, rivers
8. Which country neighbours Kenya to the north-west?
A. Somalia B. Sudan C. Uganda D. Ethiopia
9. Which historical built environment is found in Mombasa?
A. Vasco da Gama Pillar
B. Jomo Kenyatta Monument
C. Fort Jesus
D. Black Hawk
10. Special houses where horticultural crops are grown are known as:
A. Greenhouses B. Huts C. Homes D. Sheds
11. Which is the smallest country in Eastern Africa?
A. Djibouti B. Sudan C. Rwanda D. Burundi
12. The other name for the Prime Meridian is:
A. Equator B. Prime Meridian
C. Greenwich Meridian D. Longitude
13. Eastern Africa lies between longitudes:
A. 22°E and 51°E B. 23°E and 12°S
C. 12°S and 22°E D. 51°E and 23°E
14. Who correctly identified three countries crossed by the Equator?
A. Mary – Uganda, South Sudan, Tanzania
B. Lemaiyan – Kenya, Ethiopia, Rwanda
C. Kamau – Kenya, Uganda, Somalia
D. Wanjiru – Somalia, Kenya, Sudan
15. The main reason for Bantu migration was:
A. Running from diseases
B. Drought and famine
C. Looking for fertile land
D. Increased population
16. Three countries crossed by the Equator in Eastern Africa are:
A. Uganda, South Sudan, Tanzania
B. Kenya, Ethiopia, Rwanda
C. Kenya, Uganda, Somalia
D. Somalia, Kenya, Sudan

17. Identify the correct parts of a volcanic mountain

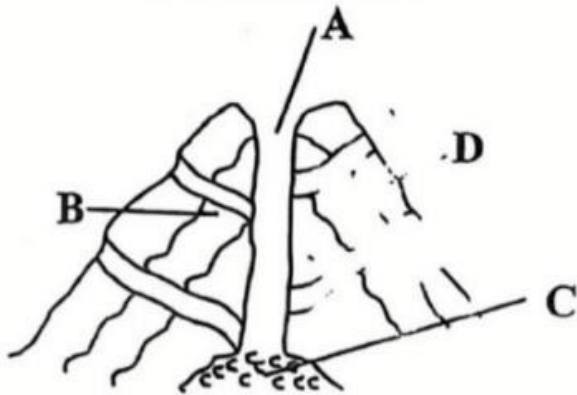

A B C D

Learners were asked by their social studies teacher to identify the parts labelled A,B,C and D of the volcanic mountain. Who among them gave the correct answer?

- A. SUSAN: Vent, crater, subsidiary vent, magma
- B. JOHN: Magma, crater, vent, subsidiary vent
- C. LENARD: Crater, vent, magma, subsidiary vent
- D. ANITA: Subsidiary vent, vent, magma, crater

18. Identify one crater lake found in Kenya.

- A. Paradise
- B. Kyoga
- C. Ngozi
- D. Shalla

19. The following describe which climatic region?

- i. Cloudless sky throughout the year
- ii. Less than 250mm rainfall
- iii. Hot and dry most months

- A. Equatorial
- B. Mountain
- C. Desert
- D. Sub-tropical

20. Which crop is not grown on a large scale?

- A. Coffee
- B. Spinach
- C. Tea
- D. Sugarcane

21. What is the capital city of the country that borders Kenya to the south?

- A. Khartoum
- B. Djibouti
- C. Addis Ababa
- D. Dodoma

22. The main reason for the migration of the Bantus was:

- A. Running away from diseases
- B. Drought and famine
- C. Increased population
- D. Looking for fertile land

23. Which is not a way of taking care of historical built environments?

- A. Destroying them
- B. Cleaning them
- C. Painting them
- D. Fencing them

24. Which mountains are block mountains (horsts)?

- A. Mt Kenya, Mt Kirisimbi, Mt Longonot
- B. Mt Ruwenzori, Mt Pare, Mt Usambara
- C. Danakil Alps, Mt Elgon, Mt Kenya
- D. Mt Longonot, Mt Usambara, Mt Meru

25. Which historical built environment is found in Rwanda?

- A. Fort Jesus Museum
- B. Roman Kiosk
- C. Kigali Genocide Memorial
- D. Black Hawk

26. Pure democracy is also called:

- A. Kenya democracy
- B. Indirect democracy
- C. Direct democracy
- D. Funny democracy

27. Which is not a method of acquiring Kenyan citizenship?

- A. Registration
- B. Dual citizenship
- C. Birth
- D. Assimilation

28. Which of the following is not a modern means of communication?

- A. Messenger
- B. Newspaper
- C. Postal service
- D. Radio

29. National days include the following except:

- A. Taifa Day
- B. Jamhuri Day
- C. Mashujaa Day
- D. Madaraka Day

30. Which factor promotes peace?

- A. Poverty
- B. Equal sharing of resources
- C. Unemployment
- D. Corruption

COMPETENCE BASED EDUCATION

GRADE 6 2026

FORMATIVE ASSESSMENT

NAME: _____ ASSESSMENT NUMBER: _____

SCHOOL: _____ DATE: _____

CRE
TIME: 1 HOUR

Exceeding Expectation	Meeting Expectation	Approaching Expectation	Below Expectation	Total Score (%)

Answer all questions.

- Which is an appropriate leisure activity?
A. Betting
B. Disco parties
C. Doing physical exercise
D. Sitting by the roadside
- When Jesus was baptized, the Holy Spirit came down in the form of a:
A. Fire
B. Cloud
C. Dove
D. Thunderstorm
- Christians celebrate the death and resurrection of Jesus during:
A. Christmas
B. Easter
C. Passover
D. Advent
- When Jesus fed the five thousand, the food came from:
A. His disciples
B. A farm
C. A little boy
D. A market
- What value do Christians learn from Ananias and Sapphira?
A. Tolerance
B. Mercy
C. Perseverance
D. Honesty
- The first disciples to be called by Jesus were:
A. James and John
B. James and Simon
C. Simon and Andrew
D. Andrew and Philip
- Who helped Jesus carry the cross?
A. John
B. Peter
C. Joseph of Arimathea
D. Simon of Cyrene
- Who built the temple in Jerusalem?
A. Solomon
B. Ahab
C. David
D. Saul
- On the fourth day of creation, God created:
A. Birds and sea creatures
B. Land and animals
C. Light and darkness
D. Sun, moon and stars
- Which commandment has a promise?
A. Worship no other god
B. Do not commit adultery
C. Keep the Sabbath holy
D. Honour your father and mother
- The pure in heart shall:
A. See God
B. Inherit the earth
C. Be comforted
D. Be called sons of God
- Which is not a quality of a good leader?
A. Orderly and sober
B. Mature in faith
C. Drunkard and violent
D. Trustworthy

13. Who led the Israelites out of Egypt?

- A. Abraham
- B. Moses
- C. David
- D. Joseph

14. Jesus was born in:

- A. Jerusalem
- B. Nazareth

C. Bethlehem

D. Egypt

15. The Bible is divided into:

A. Two Testaments

B. Three books

C. Four Gospels only

D. Five sections

COMPETENCE BASED EDUCATION

GRADE 6 2026

FORMATIVE ASSESSMENT

NAME: _____ ASSESSMENT NUMBER: _____

SCHOOL: _____ DATE: _____

IRE

TIME: 1 HOUR 40 MINUTES

Exceeding Expectation	Meeting Expectation	Approaching Expectation	Below Expectation	Total Score (%)

Answer all questions.

- The migration of the Prophet (S.A.W) from Makkah to Madinah is called:
A. Hajj
B. Arafat
C. Miraaj
D. Hijrah
- Which Surah warns against backbiting and slander?
A. Maun
B. Nas
C. Humaza
D. Takathur
- Which Surah of the Qur'an is named after an animal?
A. Fatiha
B. Fil
C. Ikhlas
D. Taubah
- The special Sunnah prayer performed during the month of Ramadhan is known as:
A. Dhuhr
B. Witr
C. Taraweh
D. Eid
- The Hadith says: "Seeking knowledge is obligatory upon every _____."
A. Woman
B. Male
C. Muslim
D. Child
- Medium impurity (najasat) is referred to as:
A. Mughaladha
B. Mutawasita
C. Khafif
D. Hadithi
- Which angel is in charge of guarding Hellfire?
A. Munkar
B. Mikail
C. Malik
D. Atid
- The Muhajirun were the:
A. Helpers from Madinah
B. Fighters in battles
C. Migrants from Makkah
D. Workers in Madinah
- The best way to show gratitude for Allah's blessings is to:
A. Use them as you wish
B. Use them responsibly to please Allah
C. Benefit your family only
D. Show off to others
- Which Surah translates to "The Terrible Calamity"?
A. Al-Qariah
B. An-Nas
C. Al-Humaza
D. At-Takathur
- The first pillar of Islam is:
A. Salah
B. Zakah

- C. Shahada
 - D. Sawm
12. The holy book of Muslims is called:
- A. Taurat
 - B. Injil
 - C. Zabur
 - D. Qur'an
13. How many obligatory prayers do Muslims perform daily?
- A. Three
 - B. Four
 - C. Five
 - D. Six
14. Zakah is given to:
- A. The rich
 - B. The poor and needy
 - C. Traders only
 - D. Children only
15. The night journey of the Prophet (S.A.W) is known as:
- A. Hijrah
 - B. Isra wal Miraaj
 - C. Badr
 - D. Uhud
16. Fasting in the month of Ramadhan is called:
- A. Zakah

- B. Hajj
 - C. Sawm
 - D. Sunnah
17. The Kaaba is found in:
- A. Madinah
 - B. Jerusalem
 - C. Taif
 - D. Makkah
18. The angel who brought revelation to the Prophet (S.A.W) was:
- A. Israfil
 - B. Jibril
 - C. Mikail
 - D. Malik
19. Performing ablution before prayer is called:
- A. Tayammum
 - B. Ghusl
 - C. Wudhu
 - D. Dhikr
20. The helpers of Madinah were known as:
- A. Muhajirun
 - B. Ansar
 - C. Tabiin
 - D. Sahabah

COMPETENCE BASED EDUCATION

GRADE 6 2026

FORMATIVE ASSESSMENT

NAME: _____ ASSESSMENT NUMBER: _____

SCHOOL: _____ DATE: _____

MATHEMATICS

TIME: 1 HOUR 40 MINUTES

Exceeding Expectation	Meeting Expectation	Approaching Expectation	Below Expectation	Total Score (%)

Answer all questions.

- Identify the digit in the ten-thousands place value in the number **7,693,024**.
A. 6 B. 9 C. 3 D. 7
- In a school there were **843,062** learners. What is the total value of digit **0**?
A. 0 B. 3,000
C. Hundreds D. Tens
- Arrange the following numbers in ascending order:
99,999; 100,000; 99,909; 100,001; 100,900
A. 99,909; 99,999; 100,000; 100,001; 100,900
B. 99,999; 99,909; 100,000; 100,001; 100,900
C. 100,900; 100,001; 100,000; 99,999; 99,909
D. 99,909; 100,000; 99,999; 100,001; 100,900
- Six friends saved **Sh. 399,690** in one year. Round off the amount to the nearest thousand.
A. 400,000 B. 300,000
C. 390,000 D. 399,000
- Work out: **80^2**
A. 160 B. 6,400 C. 3,200 D. 640
- A square tile is 12 cm long. What is its area in square centimetres?
A. 24 cm² B. 100 cm²
C. 144 cm² D. 144 cm
- Rashid's square plot has an area of **484 m²**. What is the length of each side?
A. 22 m B. 44 m C. 121 m D. 13 m
- A cancer awareness campaign was attended by **12,621** people. Round off to the nearest hundred.

- A. 11,000 B. 12,000
C. 12,600 D. 13,000

9. Work out: $4,012 \times 6$

- A. 24,072 B. 24,062
C. 24,081 D. 24,000

10. Samuel spends **Sh. 2,000** per month on food. How much does he spend in one year?

- A. Sh. 2,500 B. Sh. 2,400
C. Sh. 2,000 D. Sh. 24,000

11. What is the next number in the pattern?

70, 140, 210, 280, _____

- A. 40 B. 420 C. 270 D. 350

12. Work out: $910 + 1000 - 400$

- A. 535 B. 900 C. 1,510 D. 1,000

13. A milk processing company packed **2,400** packets of milk into **60** boxes equally. How many packets were packed in each box?

- A. 40 B. 60 C. 80 D. 50

14. During a prize-giving day, **2,390** loaves of bread were shared equally among **410** learners. How many loaves remained?

- A. 340 B. 5 C. 210 D. 100

15. Find the perimeter of the shape shown

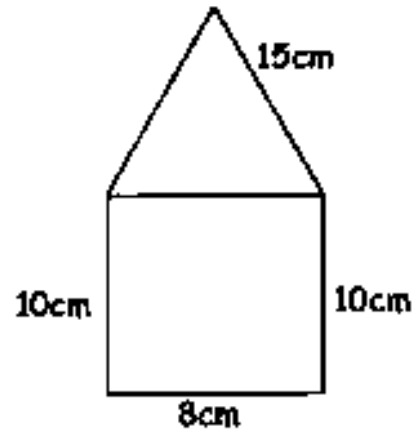

- A. 43 cm B. 48 cm C. 50 cm D. 58 cm

16. Work out: $24 \div 3 + 9 \times 6 - 4$

- A. 8 B. 26 C. 58 D. 98

17. Find the area of the shaded part

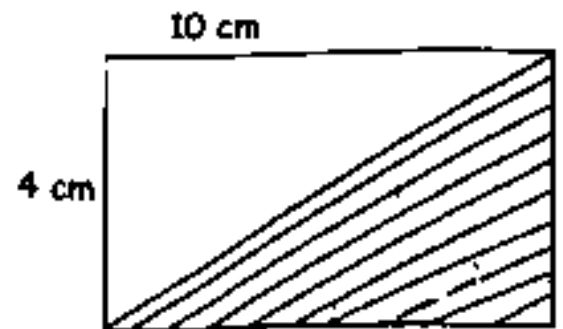

- A. 20 cm^2 B. 40 cm^2 C. 20 cm D. 80 cm^2

18. Jane made 20 litres of tea. She used 15 litres of water and the rest was milk. How much milk was used as a decimal?

- A. 0.25 B. 0.5 C. 0.75 D. 0.84

19. In Weru Primary School, **0.74** of the learners are boarders. What percentage is this?

- A. 30% B. 74%
C. 26% D. 50%

20. Work out: $16.3066 + 18.44$

- A. 32.8246 B. 16.4910
C. 35.7466 D. 34.7466

21. Find the sum of: $\frac{5}{6} + \frac{4}{9}$

- A. $\frac{13}{36}$ B. $\frac{20}{36}$
C. $\frac{29}{36}$ D. $\frac{6}{36}$

22. A skipping rope is **12.438 m** long. Round off to 2 decimal places.

- A. 12.44 m B. 12.4 m
C. 12.43 m D. 12.48 m

23. Find the volume of a cuboid below

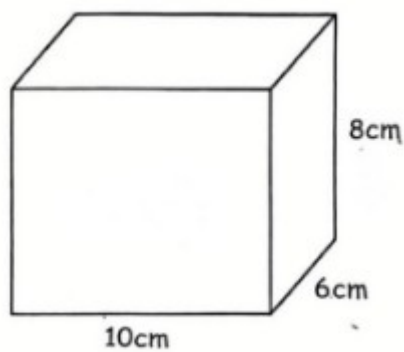

- A. 48 cm B. 480 cm^2
C. 480 cm^3 D. 24 cm^3

24. Subtract **114.3478** from **207.529**.

- A. 93.1812 B. 89.1111
C. 90.1813 D. 321.8768

25. John's height is **145 cm 7 mm**. What is his height in millimetres?

- A. 145 mm B. 1,457 mm
C. 152 mm D. 14,507 mm

26. The height of water in a dam increased by 5 cm. What is this increase in millimetres?

- A. 50 mm B. 500 mm
C. 5,000 mm D. 50,000 mm

27. What is the shortest possible length of a rope from which equal pieces of 15 cm, 20 cm and 40 cm can be cut?

- A. 100 cm B. 120 cm C. 60 cm D. 75 cm

28. How many of containers (B) are needed to fill container (A)?

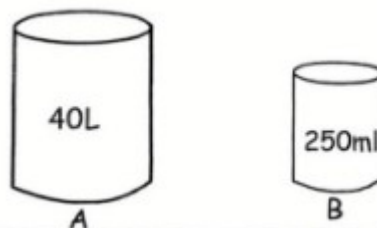

- A. 16 B. 320
C. 160 D. 80

29. Sand weighs **18 tonnes 481 kg** and small stones weigh **12 tonnes 394 kg**. What is the total mass?

- A. 30 tonnes 875 kg
B. 30 tonnes 775 kg
C. 20 tonnes 875 kg
D. 6 tonnes 87 kg

30. Read the time shown on the clock face provided.



- A. 2:35
B. 7:10
C. 3:35
D. 7:15

ELIMU MSINGI KWA MISINGI YA UMAHIRI

GREDI 6 2026

TATHMINI ENDELEVU

JINA: _____ **NAMBARI YA TATHMINI:** _____

SHULE: _____ **TAREHE:** _____.

Kuzidisha matarajio	Kufikisha matarajio	Kukaribia matarajio	Chini ya matarajio	Jumla (%)

SHUGHULI ZA KISWAHILI

MUDA: SAA 1 DAKIKA 40

SEHEMU YA 1: KUFAHAMU MAZUNGUMZO

Soma mazungumzo yafuatayo kisha ujibu maswali 1 – 5:

Lisa: Acha! kabisa.

Mwalimu: (akikohoa) Samahani mwalimu, sikuona umefika.

Lisa: Mbona unafagia mahali penye vumbi hivi? Hujui vumbi ndiyo inakufanya ukohoe?

Mwalimu: Pana uchafu. Nimeona nifagie.

Lisa: Ni kweli, mwalimu, nitakuonyesha jinsi ya kupunguza vumbi unapofagia.

Mwalimu: Huongeza kwa kuwajibika, Lisa. Lakini ni muhimu kuchunga afya yako pia.

Lisa: Sawa mwalimu, lakini ulitwambia tusikae katika mazingira machafu.

1. Kwa nini Lisa alikuwa akifagia?

A) Ili kuondoa vumbi

B) Mwalimu alimtaka afagie

C) Si vizuri kukaa kwenye mazingira machafu

D) Ili mwalimu amuone

2. Mazungumzo haya yalifanyika wapi?

- A) Nyumbani B) Shuleni
- C) Hospitalini D) Kortini

3. Kwa nini Lisa alikuwa akikohoa?

- A) Alitaka ruhusa ya kwenda hospitalini
- B) Mwalimu alimwathibu
- C) Mazingira yake yalikuwa machafu
- D) Alikuwa akifagia mahali penye vumbi

4. Tunaweza kusema Lisa ni mwanafunzi:

- A) Mvivu B) Mzembe
- C) Mtiifu D) Mchangamfu

SEHEMU YA 2: KUFAHAMU KIFUNGU

Turo na Turi ni marafiki sana. Wanapendana kama chanda na pete. Turo ni mrefu na mnene. Ana ngozi ya maji ya kunde. Turi ni mfupi kama nyundo. Yeye ni mweusi ti ti ti. Macho yake madogo yanapendeza. Turo na Turi wanaishi katika Kijiji Mato na wanasoma katika shule ya msingi ya Mwendo wa kasi. Turo ni hodari katika Hisabati. Turi naye ni hodari kwa mchezo wa kandanda. Wavulana hawa wawili wanatia bidii michezoni na masomoni. Mwalimu Moshi anawahimiza kuwa michezo ni muhimu kama vile masomo. Bi Moshi hupenda kutoa mfano wa mwanariadha Kipchoge ambaye amefaulu maishani kwa ajili ya talanta yake ya mbio.

6. Turo na Turi walipendana kama chanda na pete. Ina maana gani?

- A) Wanapendaa kuvaa pete
- B) Wanapendana sana
- C) Wanapendana kwa ajili ya pete
- D) Pete zao ni nzuri

7. Turo alikuwa hodari katika:

- A) Hisabati B) Kandanda
- C) Riadha D) Kandanda na Riadha

8. Mwalimu Moshi anawahimiza kuwa:

- A) Masomo ni bora zaidi kuliko michezo
- B) Ni vema kutia bidii masomoni na kuacha michezo

SEHEMU YA 3: KUFAHAMU KIFUNGU CHA SHEREHE

5. Taja msamiati wa adabu ulio tumika katika mazungumzo haya:

- A) Hongera
- B) Acha!
- C) Mbona
- D) Samahani

C) Michezo na masomo yote ni muhimu

D) Michezo haiwezi kukufanya mtu wa maana

9. Turo na Turi ni:

- A) Wavulana B) Mvulana na msichana
- C) Wasichana D) Walimu

10. Bi Moshi hupenda kutoa mfano wa nani?

- A) Rais Ruto B) Kipchoge
- C) Turi D) Jena

Kesho ni Ijumaa. Itakuwa sikukuu ya mashujaa nchini. Kutakuwa na sherehe ya kuadhimisha siku hiyo. Jena na Joana watakariri shairi kuhusu mashujaa. Tangu juzi wamekuwa wakifanya mazoezi ili kujiandaa. Mtondogoo watarejea shuleni watawasimulia wenzao kuhusu matukio ya siku hiyo.

11. Jena na Joana watarejea shuleni mtondogoo siku gani?

- A) Jumamosi B) Jumapili
C) Jumatatu D) Jumanne

12. Mtu anayeipenda nchi yake huitwa:

- A) Kiongozi B) Mzalendo
C) Katili D) Jasusi

13. Chagua vitendo vinavyoonyesha kuwa Jena na Joana wanapenda nchi yao:

- A) Kuhudhuria sherehe, kukariri shairi
B) Kurejea shuleni kukariri shairi
C) Kusimulia matukio, kuhudhuria sherehe
D) Kusimulia matukio, kurejelea shuleni

14. Maana ya kujiandaa kulingana na kifungu hiki ni:

- A) Kujitambulisha B) Kujinufaisha
C) Kujitayarisha D) Kujiburudisha

15. Mada ya shairi litakalokaririwa ni ipi?

- A) Kenya B) Kujitayarisha
C) Jena na Joana D) Sikukuu ya Mashujaa

SEHEMU YA 4:

16. Alipotoka _____ hospitalini tulienda.

- A) Alitoka B) Alijitoa
C) Alipoka D) Alifika

17. Kumzika = _____

18. Kwangu = _____

19. Ya = _____

20. Yenye = _____

SEHEMU YA 5: MAJIBU YA KIANGALIFU

21–30: Jibu kulingana na maagizo.

21. Kila mmoja anapitia mlango huo.

- A) Kifo B) Kanisa C) Darasa D) Nyumba

22. Andika sentensi ifuatayo katika wingi:

Chumba kile kidogo kimeangukia chungu.

- A) Chumba vile vidogo vimeangukia chungu
B) Chumba vile kidogo vimeangukia chungu
C) Vyumba vile vidogo vimeangukia vyungu

23. Chagua aina ya nomino dhahania:

Gavana alieleza namna ya kupunguza umaskini

- A) Umaskini B) Gavana
C) Namna D) Alieleza

24. Kitambaa kina madoadoa mengi mekundu.

Tumia kivumishi kiashiria kujaza nafasi:

- A) Kipya
B) Hiki
C) Kilichopigiwa mstari
D) Kilichokuwa

25. Andika katika hali ya ukubwa:

Mtoto mzuri anasoma

- A) Toto zuri linasoma
B) Toto mzuri anasoma
C) Kitoto kizuri kinasoma
D) Kitoto zuri kinasoma

26. Chai ilikuwa tamu ilipotiwa sukari. Aina gani ya kivumishi?

- A) Tamu
B) Ilipotiwa

ÉDUCATION BASÉE SUR LES COMPÉTENCES

GRADE 6 2026

FORMATIVE ASSESSMENT

NOM: _____ NUMÉRO D'ÉVALUATION: _____

ÉCOLE: _____ DATE: _____.

FRENCH

TEMPS : 1 HEURE 40 MINUTES

Dépasse les attentes	Atteint les attentes	Approche des attentes	En dessous des attentes	Score total (%)

Répondez à toutes les questions.

A. Read the story and complete using the words given.

Words: (Nairobi, français, dix, St. Patrick, m'appelle)

Bonjour. Je _____ Marie. J'ai _____ ans. Je suis kenyane.

J'habite à _____ avec ma famille.

Je parle swahili, anglais et _____.

Mon école s'appelle _____.

B. Write the jumbled *ma famille* words correctly.

erem → _____

cleno → _____

rrefe → _____

atent → _____

C. Write 3 *animaux domestiques* in French.

a) _____

b) _____

c) _____

D. Translate to French.

a) Sweep the class – _____.

b) Collect the papers – _____.

c) Close the door – _____.

d) Sit down – _____.

e) Clap your hands – _____.

G. Change the following polite words to English.

Merci – _____

S'il vous plaît – _____

Désolée – _____

F. Write 3 sentences about your teacher in French. (Mon professeur)

COMPETENCE BASED EDUCATION

GRADE 6 2026

NAME: _____ ASSESSMENT NUMBER: _____

SCHOOL: _____ DATE: _____

SCIENCE AND TECHNOLOGY

TIME: 1 HOUR 40 MINUTES

Answer all questions.

- Which of the following is NOT a characteristic of plants as living things?
A) They grow and develop
B) They move from place to place
C) They reproduce
D) They respond to environmental changes
- After eating meat, digestion mainly takes place in the:
A) Mouth
B) Oesophagus
C) Stomach
D) Large intestine
- Which pair of substances has definite shape and definite volume?
A) Water and milk
B) Air and smoke
C) Book and stone
D) Juice and porridge
- All the following affect whether an object sinks or floats EXCEPT:
A) Density B) Shape C) Weight D) Colour

- Materials that allow light to pass through clearly are known as:
A) Opaque B) Translucent
C) Transparent D) Reflective
- A metal rod heated at one end becomes hot at the other end.

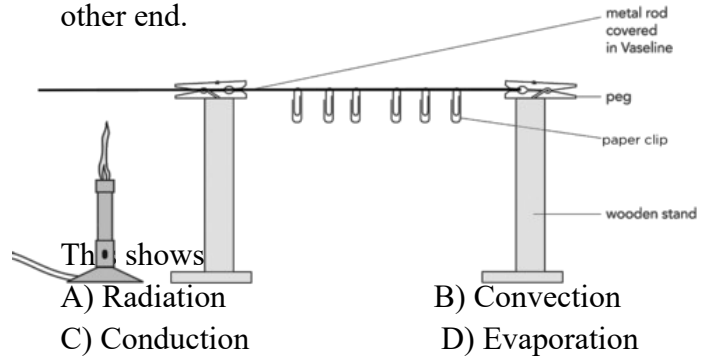

- Clouds that form in flat layers across the sky are called:
A) Cumulus B) Stratus C) Cirrus D) Nimbus
- When a learner warms herself near a fire, heat reaches her mainly by:
A) Conduction and convection
B) Radiation and convection
C) Conduction only
D) Radiation only

9. Which of the following is NOT a main feature of a Scratch project?
 A) Stage
 B) Sprites
 C) Script
 D) Monitor
10. Which animal is cold-blooded, has dry scales, breathes using lungs, and lays eggs?
 A) Frog B) Fish C) Snake D) Whale
11. The teacher heated water in a glass container as shown

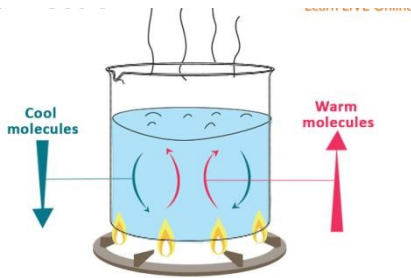

Heating water in a container demonstrates heat transfer by:

- A) Conduction in solids B) Radiation in liquids
 C) Convection in liquids D) Reflection in liquids
12. Valves that prevent backflow of blood are found in the:
 A) Arteries only B) Veins only
 C) Capillaries D) Aorta
13. Which of the following is NOT a function of roots?
 A) Anchorage B) Absorption of water
 C) Photosynthesis D) Storage of food
14. When leaves are covered with a clear polythene bag, droplets form inside. This shows:
 A) Photosynthesis B) Transpiration
 C) Respiration D) Germination
15. Which pair of animals belongs to the same group?
 A) Cow and goat B) Spider and tick
 C) Snail and snake D) Lizard and frog
16. Some mushrooms should not be eaten because they are:
 A) Poisonous B) Sweet
 C) Expensive D) Soft

17. The urethra is a tube that allows:
 A) Production of sperms
 B) Passage of urine only
 C) Passage of urine and sperms in males
 D) Production of semen
18. Which of the following is NOT a type of muscle?
 A) Skeletal
 B) Smooth
 C) Cardiac
 D) Skull
19. Reflected sound is known as:
 A) Vibration B) Echo
 C) Force D) Pitch
20. Which statement does NOT describe the trachea?
 A) It has C-shaped cartilage rings
 B) It is also called the windpipe
 C) It contains mucus and tiny hairs
 D) It pumps blood
21. Grade 6 learners drew the heart as shown below.

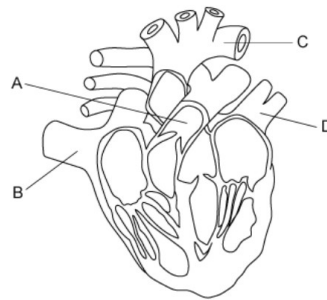

The venacava is laelled?

- A) A B) B C) C D) D
22. Blood that carries little oxygen is called:
 A) Oxygenated blood
 B) Deoxygenated blood
 C) Plasma
 D) Serum
23. Blood travels from the lungs to the heart through the:
 A) Pulmonary vein B) Aorta
 C) Vena cava D) Artery
24. The upper chambers of the heart are called:
 A) Ventricles B) Arteries
 C) Atria D) Capillaries

25. The different shapes of the Moon seen from Earth during a month are called:

- A) Eclipses
- B) Shadows
- C) Faces
- D) Phases

COMPETENCE BASED EDUCATION

GRADE 6 2026

FORMATIVE ASSESSMENT

NAME: _____ **ASSESSMENT NUMBER:** _____

SCHOOL: _____ **DATE:** _____

AGRICULTURE AND NUTRITION

TIME: 1 HOUR 40 MINUTES

Exceeding Expectation	Meeting Expectation	Approaching Expectation	Below Expectation	Total Score (%)

Answer all questions.

1. Which of the following is NOT a method of controlling soil erosion?
 - A) Planting cover crops
 - B) Constructing gabions
 - C) Applying mulch
 - D) Overgrazing land
2. The following is a type of soil erosion



Soil erosion is called:

- A) Splash erosion
 - B) Rill erosion
 - C) Gully erosion
 - D) Sheet erosion
3. Which of the following is NOT a method of conserving water on the farm?
 - A) Mulching
 - B) Shading the soil
 - C) Planting cover crops
 - D) Cutting unnecessary branches
 4. The process of soil being carried and deposited in another place is known as:
 - A) Soil pollution
 - B) Soil conservation
 - C) Soil erosion
 - D) Soil deposition

5. The most appropriate way to protect crops from birds is by:
 - A) Killing them
 - B) Poisoning them
 - C) Scaring them away
 - D) Fencing the whole farm
6. Removing unwanted plants from a crop field is known as:
 - A) Weeding
 - B) Pruning
 - C) Harvesting
 - D) Mulching
7. A structure made to scare birds and small animals away from crops is called a:
 - A) Feeding trough
 - B) Thorn fence
 - C) Scarecrow
 - D) Animal trap
8. Sunken seedbeds are prepared by:
 - A) Lowering the soil surface below the surrounding land
 - B) Raising soil above ground level
 - C) Using trays for seedlings
 - D) Digging holes for planting trees
- 9.
10. The farm tool shown in the diagram is a:



- A) Shovel
- B) Bucket
- C) Watering can
- D) Storage pot

11. The tool mentioned above is mainly used for:
 - A) Digging soil
 - B) Cooking food
 - C) Watering crops
 - D) Storing grains
12. Water that flows over the soil surface without being absorbed is called:
 - A) Irrigation
 - B) Soil conservation
 - C) Soil erosion
 - D) Runoff
13. In a compost pit, the layer marked A may contain:

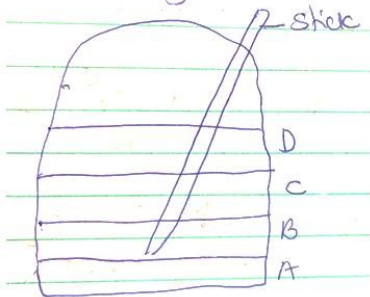

- A) Dry plant materials
- B) Plastics
- C) Stones
- D) Metal scraps

14. Which domestic animal provides both milk and mohair?
 - A) Sheep
 - B) Rabbit
 - C) Cow
 - D) Goat
15. The practice of removing excess seedlings to avoid overcrowding is called:
 - A) Thinning
 - B) Mulching
 - C) Gapping
 - D) Weeding
16. Which of the following is NOT a climbing plant?
 - A) Passion fruit
 - B) Grapes
 - C) Blackberries
 - D) Guava
17. Which of the following is NOT used as a household fuel?
 - A) Charcoal
 - B) Electricity
 - C) Gas
 - D) Water
18. Which pair of stitches is commonly used in joining garments?
 - A) Tacking and hemming
 - B) Backstitch and oversewing
 - C) Chain stitch and loop stitch
 - D) Backstitch and chain stitch
19. Which of the following is NOT a good hygiene practice when preserving fruits and vegetables?
 - A) Using clean storage containers
 - B) Washing hands before handling
 - C) Leaving produce uncovered
 - D) Washing fruits with clean water
20. Which of the following is NOT a proper practice when stewing food?
 - A) Cleaning ingredients before cooking
 - B) Using clean utensils
 - C) Cooking with excessive heat
 - D) Covering the cooking pot
21. Preserving fruits and vegetables is important because it helps to:
 - A) Soften them
 - B) Improve their sweetness
 - C) Increase their shelf life
 - D) Change their colour
22. The most suitable method of preparing mandazi is:
 - A) Shallow frying
 - B) Deep frying
 - C) Boiling
 - D) Roasting
23. A traditional structure used to store cereals and pulses is called a:

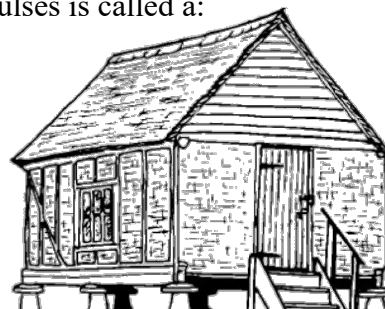

A) House B) Hutch C) Granary D) Hut

24. Which of the following is NOT a benefit of giving special care to garments?

- A) Killing germs B) Whitening clothes
C) Removing stains D) Shortening their lifespan

25. The stage of growth between childhood and adolescence is known as:

- A) Puberty B) Adulthood
C) Pre-teen stage D) Infancy

26. Which of the following foods is a good source of vitamins?

- A) Kales B) Rice
C) Bread D) Meat

COMPETENCE BASED EDUCATION

GRADE 6 2026

FORMATIVE ASSESSMENT

NAME: _____ ASSESSMENT NUMBER: _____

SCHOOL: _____ DATE: _____

ENGLISH

TIME: 1 HOUR 40 MINUTES

Exceeding Expectation	Meeting Expectation	Approaching Expectation	Below Expectation	Total Score (%)

Answer all questions.

SECTION A: COMPREHENSION

Hare and Elephant

A long time ago, Hare owned many acres of fertile land in Koola Plains. He grew millet, sorghum, and pumpkins. Hare's family would come together to plant, weed, and harvest. Every market day, they would arrive early at Makongo market to sell their produce.

"The early bird catches the worm," Hare often told his children when waking them up at the crack of dawn to work on the plantation.

"Nothing worth having comes easy. No pain, no gain." Lazy Elephant lived across River Nzeeu. Laziness is the enemy of goodness. Elephant used to steal Hare's pumpkins. One day, Hare called a family meeting. He was convinced that unity is strength.

"I will hide in one of the pumpkins and wait," he told them. "When Elephant swallows the pumpkin, I will scare him."

"Carry your drum," Mrs. Hare suggested.

Questions

1. Identify the crops grown by Hare.
2. List 2 proverbs used in the passage:
 - i) _____
 - ii) _____
3. Write the meaning of the following words/phrases:
 - a) Crack of the dawn _____
 - b) Plantation _____
4. Write the best title for the passage _____

Covid-19

Murega was at home when the announcement was made. The president said all schools should close due to the threat of Covid-19. Covid-19 is an infection that causes breathing problems.

To prevent the spread, people were asked to maintain social distance, wash hands regularly, and use sanitizers.

That Monday, Murega and his cousin Mbatia did not go to school. They were happy about staying home, but after the second week, their excitement died down. For the rest of the year, they had to stay home. Those who did not stay home were taken to quarantine centres for 14 days.

The disease affected the whole world. News of many deaths made countries restrict movement in and out of their borders.

Questions

5. Who announced that there would be no school?

6. State two things people were advised to do to prevent the disease from spreading.

i. _____.

ii. _____.

7. Write two ways to stop the spread of communicable diseases like Covid-19.

i. _____.

ii. _____.

8. What is Covid-19?

9. For how long were the infected people kept for recovery?

10. What was the name of the centres where infected people were kept?

Complete the Story

Once upon a time, ____ (11) ____ was a very lazy man. ____ (12) ____ would always look for an easier way to feed ____ (13) _____. One day, while searching for ____ (14) ____, he saw a fruit farm. He looked around and did not see anyone. To eat, he ____ (15) ____ the fruit on the trees, so he quickly decided to steal some fruits.

Choose the best options:

- | | | | |
|------------------|---------------|-------------|---------------|
| 11. A) Their | B) They | C) There | D) They're |
| 12. A) Whom | B) Who | C) Which | D) Whose |
| 13. A) Himself | B) Itself | C) Herself | D) Themselves |
| 14. A) Something | B) Everything | C) Anything | D) Nothing |
| 15. A) Watching | B) Viewing | C) Guarding | D) Keeping |

SECTION B: GRAMMAR AND VOCABULARY

16. Complete the proverb: A rolling stone

- _____
- A) There is no stress B) Knocks on things
C) There is a slope D) Gathers no moss

17. Complete the proverb: Where there is smoke

- A) There is war B) There is soap
C) There is fire D) There is honey

18. Complete the proverb: A stitch in time

- _____
- A) Saves nine B) Saves a cloth
C) Is quite costly D) Mends cloth

Complete the collective nouns:

19. A _____ of cotton

- A) Bale B) Bell C) Bail D) Ball

20. A _____ of locusts

- A) Swum B) Swarm C) Swim D) Swam

21. A _____ of ships

- A) Galaxy B) Fleet C) Flock D) Bench

Pick the correct order of adjectives:

23. The children were playing with a _____ ball.

- A) Small, leather, green
B) Leather, small, green
C) Leather, green, small
D) Small, green, leather

24. Our headteacher has a _____ car.

- A) Big, Japanese, new, white
B) Big, Japanese, white, new

COMPOSITION

Write an interesting composition beginning in the following sentence

James woke up very early that morning. The sun was just rising,

C) Big, new, white, Japanese

D) Big, white, new, Japanese

25. The carpenter made a _____ table.

- A) Nice, large, wooden, dining
B) Nice, wooden, dining, large
C) Wooden, dining, large, nice
D) Wooden, large, dining, nice

Question Tags

26. It is likely to rain this afternoon, _____?

- A) Didn't it? B) Is it? C) Will it? D) Isn't it?

27. I am taking part in the contest, _____?

- A) Amn't I? B) Aren't I? C) Am I? D) Don't I?

28. We have worked very hard, _____?

- A) Haven't we? B) Are we?
C) Didn't we? D) Have we?

Complete using past tenses

29. He _____ (Ask) a lot of questions.

- A) Questioning B) Asked C) Asking D) Convey

30. My mom _____ the best cakes.

- A) Baked B) Asked C) Cooking D) Baking

COMPETENCE BASED EDUCATION

GRADE 6 2026

FORMATIVE ASSESSMENT

NAME: _____ **ASSESSMENT NUMBER:** _____

SCHOOL: _____ **DATE:** _____.

CREATIVE ARTS

TIME: 1 HOUR 40 MINUTES

Exceeding Expectation	Meeting Expectation	Approaching Expectation	Below Expectation	Total Score (%)

Answer all questions.

1. Kamau collected the following materials:

i) Picture cut-outs

ii) Adhesives

iii) Manila paper

Which paper-making technique did he want to practise?

A. Montage B. Collage C. Stippling D. Sticking

2. Primary colours when mixed with secondary colours in equal amounts produce _____ colours.

A. Secondary B. Black C. Tertiary D. Rainbow

3. Nelson drew a diagram of a musical instrument during Creative Arts lesson.



Which musical instrument did he draw?

- A. Nzumari B. Bung'o C. Chivoti D. Biringi

4. Grade 6 learners decorated their bodies using paints during a folk dance performance. This is called:

- A. Body ornaments
B. Body costumes
C. Body colouring
D. Body adornment

5. During a swimming lesson, a girl lay on one side in the water as she swam. What is the name of this swimming stroke?

- A. Back stroke
B. Side stroke
C. Butterfly stroke
D. Breast stroke

6. What action is taken against a player who does not respect the rules of a soccer game?

- A. The player is removed from the game
B. The player is made to run around the field
C. The player's position is changed
D. The player is made the goalkeeper

7. Which sound is represented by the hand sign shown?



- A. d B. f C. s D. m

8. A person who manipulates and controls a puppet is called a:

- A. Acrobat
B. Puppeteer
C. Magician
D. Marionette

9. Douglas used the printed fabric shown to decorate a book cover.



How many motifs have been used?

- A. Two B. Three C. Nine D. Six

10. Learners were practising a single hand dig pass. Which game were they preparing for?

- A. Volleyball B. Football
C. Basketball D. Handball

11. Learners were asked to improvise a relay baton. Which material could be used?

- A. Broken glasses B. Threads
C. Maize stalks D. Old clothes

12. Wind instruments are played by:

- A. Shaking B. Hitting C. Blowing D. Plucking

13. Three of the following are benefits of songs except: Songs _____.

- A. Accuse B. Console C. Educate D. Entertain

14. Which of the following letters is an upper case letter?

- A. g B. H C. a D. b

15. Joining two pieces of leather as shown is called:



- A. Etching B. Hemming C. Thonging D. Beading

16. Drawing a wind instrument while looking at it is drawing from:

- A. Observation B. Printing
C. Memory D. Imagination

17. The volleyball skill demonstrated in the diagram is:



- A. Overarm technique
- B. Overhead pass
- C. Dig pass
- D. Underarm technique

18. Adding cut-out cloth pieces to T-shirts by stitching is called:

- A. Collage
- B. Coil
- C. Dyeing
- D. Applique

19. Which of the following is NOT a dry media used in block shading?

- A. Crayons
- B. Charcoal
- C. Pencils
- D. Ink





20. When mounting artworks using window mounting technique, what is used to paste artworks?

- A. Glue
- B. Indian ink
- C. Candle wax
- D. Toothpick

21. The best material for making the membrane of a string instrument is:

- A. Leather
- B. Banana leaves
- C. Papyrus reeds
- D. Sugar paper

22. Which one of the following notes represents the half note?

- A 
- B 
- C 
- 

D

23. Which pass is used to pass a ball over a short distance?

- A. Overarm pass
- B. Underarm pass
- C. Chest pass
- D. Bounce pass

24. Which pair of materials is suitable for making a wristband?



- A. Leather and beads
- B. Wax and glue
- C. Beads and plastic
- D. Hard paper and leather

25. Which of the following can be decorated using applique?

- A. Book jackets
- B. Clay materials
- C. Finished woodwork items
- D. Plastic items

26. The commands “On your marks, set, go” are associated with:

- A. Swimming in deep ends
- B. Gymnastics
- C. Jumping for height
- D. Sprint races

27. How many players are expected in a handball court at the beginning of a match?

- A. Fourteen
- B. Seven
- C. Eleven
- D. Twenty-two

28. The player shown is practising:



A. Sprints B. Shot put C. Javelin D. Long jump

29. When three people sing a three-part song, they are singing in a:

A. Pair B. Solo C. Trio D. Duet

30. Still-life drawing means:

A. Drawing small objects
B. Drawing non-moving objects
C. Drawing living organisms
D. Drawing objects of different shapes and sizes

31. Which of the following is NOT a factor to consider when painting pictorial compositions?

A. Centre of interest B. Subject matter
C. Proportionality D. Contrasting colours

32. Equipment used in high jump includes all except:

A. Cross bar B. Tape measure
C. Take-off board D. Landing mat

33. Boys under 13 years use a shot weighing:

A. 3 kg B. 5 kg C. 7.26 kg D. 15 kg

34. The following are ways of making tie and dye patterns except:

A. Folding B. Knotting
C. Scratching D. Tying objects

35. Which principle of art was lacking in the diagram?



A. Proportion B. Balance C. Rhythm D. Space

36. A song praising a country and its beauty is a:

A. Patriotic song B. Lullaby
C. Topical song D. Religious song

37. Which community uses the indigenous instrument shown?

A. Luhya B. Ameru C. Kamba D. Kisii

38. A string instrument is tuned by:

A. Putting it near heat
B. Changing strings
C. Wiping the resonator
D. Tightening or loosening the strings

39. Which material is NOT needed to make improvised crayons?

A. Candle wax B. Pigments
C. Clay soil D. Beeswax

40. Where should a volleyball player stand when serving?

A. Under the net
B. Anywhere in the court
C. At the attack line
D. Behind the service line

41. A football player (not a goalkeeper) cannot use which body part to stop the ball?

A. Hands B. Head C. Thighs D. Legs

42. Joint pain, swelling and stiffness indicate which injury?

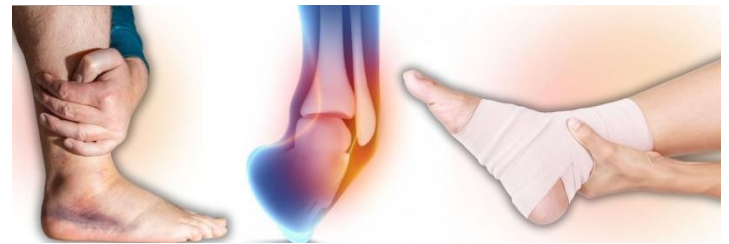

A. Fainting B. Sprain C. Bruises D. Fracture

43. Why are paraffin and beeswax mixed when making crayons?

A. To prevent burns
B. To create shapes

- C. To make crayons smoother
- D. To hold reaction firmly

44. Which tool is NOT used in carving a wooden ladle?

- A. Gouge
- B. Chisel
- C. Wood carving knives
- D. Scissors

45. Applying even force when pulling thongs through punched holes is called:

- A. Overcoat
- B. Stitching
- C. Skiving
- D. Sagging

46. Which is NOT an aspect of a folk song?

- A. Appreciation
- B. Instrumentation
- C. Message
- D. Participants

47. Which cue word shows gradually getting louder?

- A. Phrasing
- B. Diminuendo
- C. Crescendo
- D. Voice blending

48. The gymnast shown is performing a:

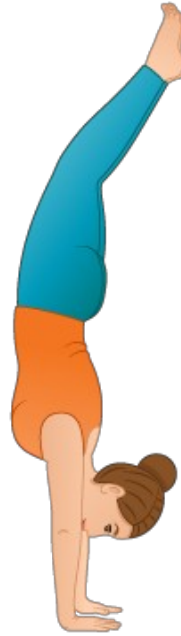

- A. Headstand
- B. Handstand
- C. Inverted stand
- D. Hand and head stand

49. A swimmer lying on one side in water for life saving uses:

- A. Breaststroke
- B. Back stroke
- C. Side stroke
- D. Inverted backstroke

50. Which of the following is NOT a member of the East African Community?

- A. Tanzania
- B. Ethiopia
- C. Somalia
- D. South Sudan