

THE SUCCESS PATH EXAMINATION COUNCIL (SPEC)

Paving the Way to Success

232/1 PHYSICS (Theory)

PRE-MOCK EXAMINATIONS 2026

MARCH 2026

Time: 2 hours



Paper 1

232/1
4992104

Name Admission Number

School Class

Candidate's Signature Date

Instructions to candidates

- (a) Write your name and admission number in the spaces provided above.
- (b) Sign and write the date of examination in the spaces provided above.
- (c) This paper consists of **two** sections **A** and **B**.
- (d) Answer **all** the questions in section A and B in the spaces provided.
- (e) All working must be clearly shown in the spaces provided in this booklet.
- (f) *Non-programmable silent electronic calculators may be used.*
- (g) *This paper consists of 12 printed pages.*
- (h) *Candidates should check the question paper to ascertain that all the pages are printed as indicated and that no questions are missing.*

FOR EXAMINER'S USE ONLY

SECTION	QUESTIONS	MAXIMUM SCORE	CANDIDATE'S SCORE
A	1 – 14	25	
B	15	11	
	16	12	
	17	12	
	18	10	
	19	10	
TOTAL SCORE		80	



SECTION A (25mks)

Answer all the questions in this section

1. The **figure 1.0** below shows part of a vernier caliper:

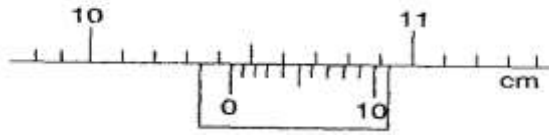

(i) What is the reading indicated by the scale? (1mark)

.....

(ii) If the vernier caliper above had a zero error of 0.02cm, what is the diameter of the object measured above? (1 mark)

.....

2. A piece of cotton thread is attached to a circular wire frame. The frame is dipped in soap solution and a soap film forms across the frame with the thread lying loosely in the film as shown in **figure 2.0** below:

fig.2

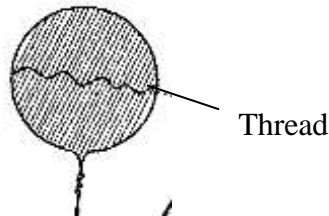

The film is pricked with a sharp hot needle at a point above the string. Draw a diagram to show the shape of the film now. (1mark)

Account for the shape you have drawn. (1mark)

.....

3. **Figure 3.0** below shows a rod made of wood on one end and metal on the other end suspended freely with a piece of thread so that it is in equilibrium;

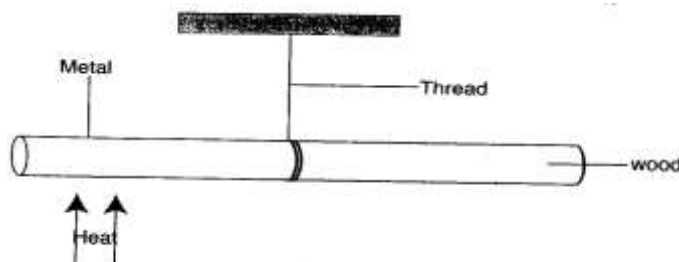

Figure 3



The side made of metal is heated with a Bunsen flame. State with reason the side to which the rod is likely to tip. (2 marks)

.....

.....

.....

4. Explain why a bubble of air increases in volume as it rises from the bottom of a pond to the surface. (1 mark)

.....

.....

5. Oil is injected at a coastal town with a speed of 12m/s where the diameter of the pipe is 7cm, flows at some point inland where the radius of the pipe is 10.5cm. Determine the speed of the oil at this point. (3 marks)

.....

.....

.....

.....

6. The **figure 4.0** below shows a tape produced by a ticker timer whose frequency is 50Hz. Determine the acceleration of the body pulling the tape. Use the scale provided. (3 marks)

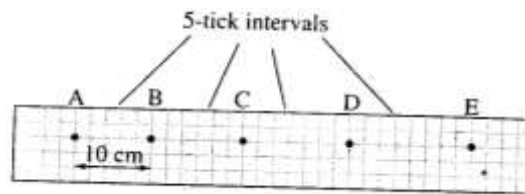

Fig 4.0

.....

.....

.....

.....

.....

.....

.....

.....



7. State **one** factor that affect the constant of a spiral spring made using a wire of a given thickness and a certain material. (1 mark)

.....

8. Identify the force that provides for the centripetal force for an electron orbiting an atomic nucleus. (1 mark)

.....

9. When a Bunsen burner is lit above a wire gauze it is observed that the flame initially burns above the gauze as shown in the figure 5(a) and 5(b) below. After sometime, the flame burns below as well as above the gauze as shown in figure 5(b)

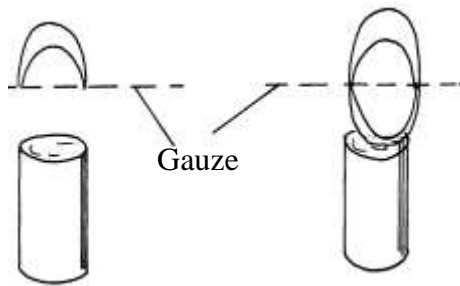

Fig.5(a)

Fig.5(b)

Explain the observation

(2 marks)

.....

10. What is the reason for milk ‘swelling’ and pouring when it is being boiled? (1 mark)

.....

11. A student inverted a rounded flask with a glass tube and inserted it into water as shown in **figure 6.0** below;

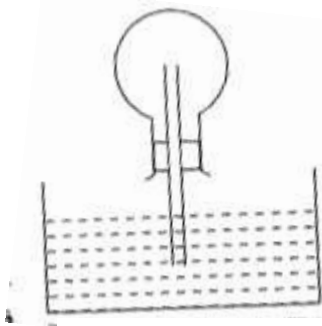

Fig.6

(a) When the student warmed the flask by rubbing it with his hands he noticed some bubbles escaping from the end of the tube into the water. Explain (1 mark)

.....

.....

(b) What happens in the glass tube when the student stops rubbing and lets the flask to cool?(1mark)

.....

.....

12. Explain how you would change the weight of a body without changing its mass. (1 mark)

.....

.....

13. It is easier to tighten and loosen nuts using a spanner with long handle than one with a short handle (1 mark)

.....

.....

14. A uniform metre rule AB whose weight is 1.8N is suspended 40cm from B as shown in **figure 7.0** below. A mass of 180g is suspended from the end B, while a block X is suspended 30cm from A.

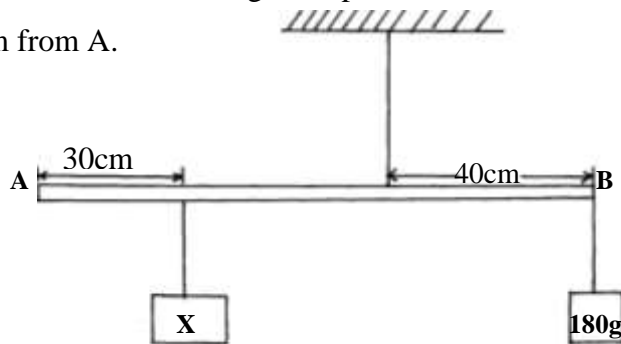

Determine the weight of the block X (3 marks)

.....

.....

.....

.....

.....

.....



SECTION B (55 MARKS)*Answer all questions in this section*

15. (a)(i) Define the term centrifugal force. (1 mark)

.....

.....

- (ii) A centrifuge containing muddy water being whirled at high speed is shown in figure below;

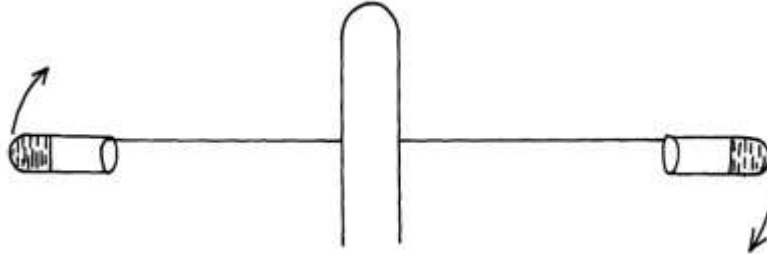

- Explain how the high speed rotation causes the separation of mud from water. (2 marks)

.....

.....

.....

- (b) Explain why a body moving in a circular path with constant speed is said to be accelerating. (1 mark)

.....

.....

- (c) A wooden block of mass 200g is placed at various distances from the centre of a turntable, which is rotating at constant angular velocity. It is found that at a distance of 8.0cm from the centre, the block just starts to slide off the table. If the force of friction between the block and the table is 0.4N, calculate;

- (i) The angular velocity of the table (3 marks)

.....

.....

.....

.....

.....

- (ii) the force required to hold the block at a distance 12cm from the centre. (2 marks)

.....

.....

.....

- (d) A stone of mass 0.5Kg is whirled in a vertical circle with a constant speed of 4m/s tracing a circle of diameter 2.4m;

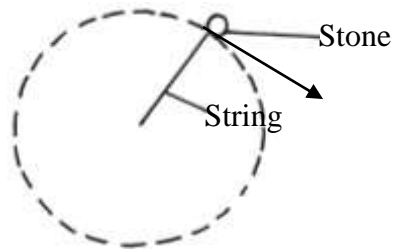

Indicate on the diagram, the position at which the string would possess: (2 marks)

(i) Maximum tension

(ii) Minimum tension

16. (a) State the law of flotation (1 mark)

.....

.....

.....

- (b) The figure below shows a rectangular metal block of density 10500Kg/m^3 and dimensions 30cm by 20cm by 20cm suspended inside a liquid of density 1200Kg/m^3 by a string attached to a point above the liquid. The three forces acting on the block are the tension T , on the string, the weight, W , of the block, and the upthrust, U , due to the liquid.

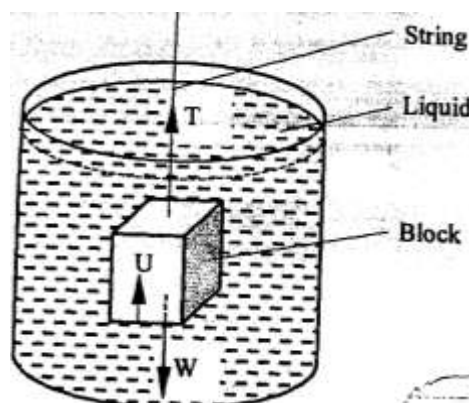

(i) Write the expression relating, T, W, and U when the block is in equilibrium inside the liquid. (1 mark)

.....
.....

(ii) Determine the weight, W, of the block (3 marks)

.....
.....
.....
.....
.....
.....
.....
.....

(iii) Determine the weight of the liquid displaced by the fully submerged block. (2 marks)

.....
.....
.....

(iv) Hence determine the tension T, in the string (2 marks)

.....
.....
.....
.....
.....

(c) A certain solid of volume 50cm^3 displaces 10cm^3 of kerosene (density 800Kg/m^3) when floating. Determine the density of the solid. (3 marks)

.....
.....
.....
.....
.....



17. (a) Define the term specific latent heat of vaporization. (1 mark)

.....
.....

(b) In an experiment to determine the specific latent heat of water, steam at 100°C was passed into water contained in a well lagged copper calorimeter. The following measurements were made:

Mass of calorimeter =50g

Initial mass of water =100g

Initial room temperature of water = 20°C

Final mass of water + calorimeter + condensed steam = 190g

(Specific heat capacity of water = 4200JK⁻¹K⁻¹)

(i) Determine the mass of condensed steam. (2 marks)

.....
.....
.....

(ii) Find the heat gained by the calorimeter and water. (5 marks)

.....
.....
.....
.....
.....
.....
.....
.....
.....
.....
.....

(iii) Given that L_v is the specific latent heat of vaporization of steam;

(I) write an expression for the heat given out by steam (1 mark)

.....
.....

(II) Determine the value of L_v (3 marks)

.....
.....
.....
.....
.....



18. A fair ground ride trolley of mass 120Kg carrying two passengers of average mass 40Kg was released at point X of a frictionless curved surface S. upon reaching the horizontal, M collided with a stationary trolley N of mass 140Kg carrying three passengers of average mass 60Kg. if the two trolleys moved off together with a common velocity along the horizontal for 1.2 seconds before coming to rest, determine:

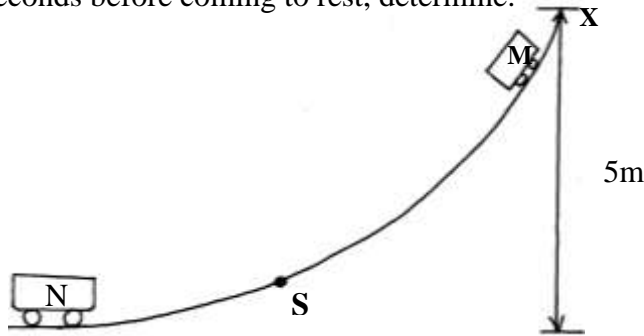

- (a) The gravitational potential energy of trolley M when at point X (2 marks)

.....

.....

.....

- (b) The velocity of M just before collision (3 marks)

.....

.....

.....

.....

- (c) The common velocity with which the two trolleys moved off along the horizontal after collisions (3 marks)

.....

.....

.....

.....

- (d) The impulse (2 marks)

.....

.....

.....



19. (a) State Boyle's law. (1 mark)

.....

.....

- (b) Some students carried out an experiment to verify Boyle's law and their results were as shown in the table below:

Pressure KN/m^2	400	320	160	180
Volume (m^3)	2.0	2.5	5.0	10.0
$\frac{1}{V}$ (m^{-3})				

- (i) Complete the table (1 mark)

- (ii) Plot a graph of pressure against $1/\text{volume}$ (4 marks)

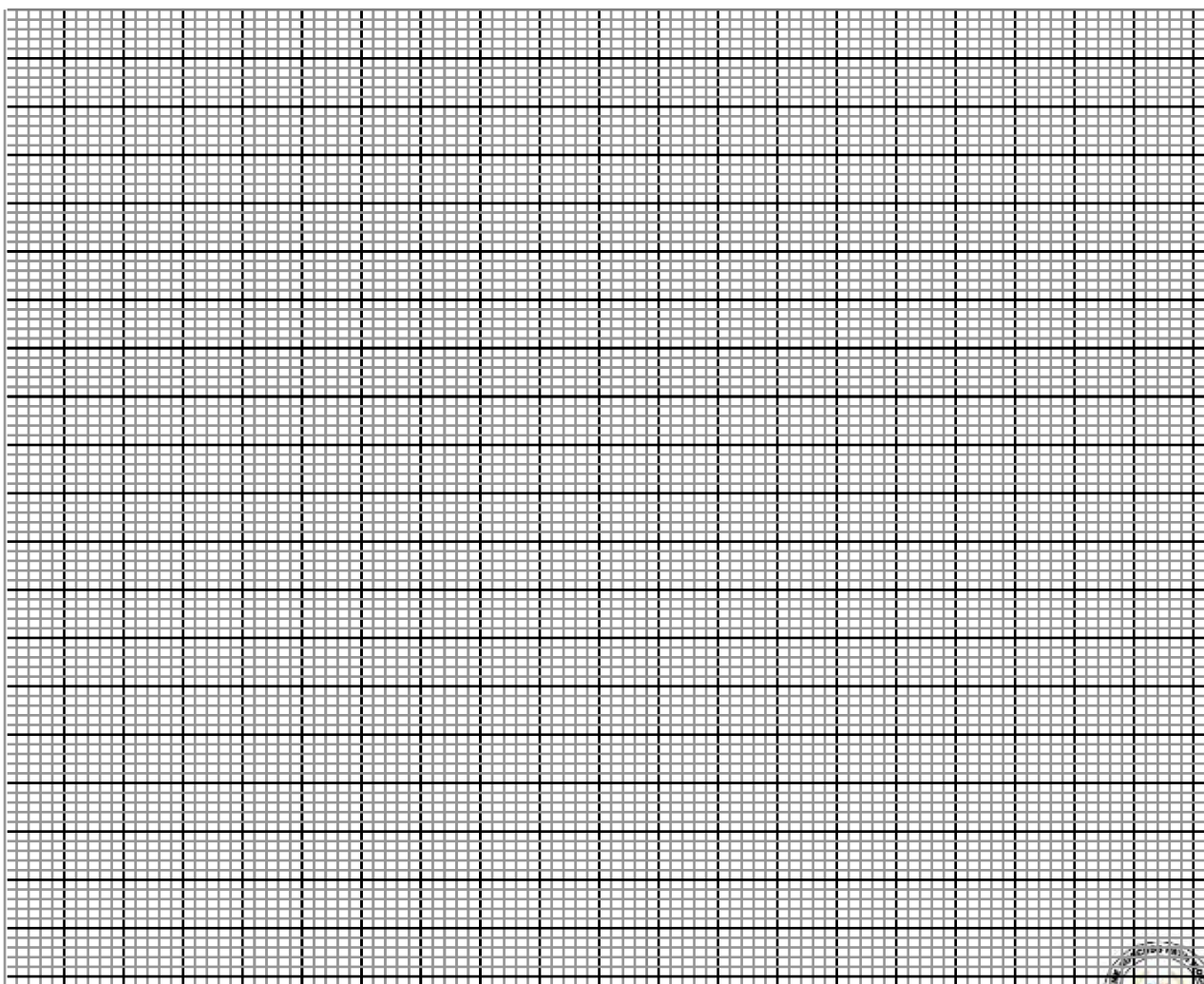

(c) Determine the gradient for the graph and state its S.I units

(2 marks)

.....

.....

.....

.....

.....

(d) A sample of gas has a pressure of $1.0 \times 10^5 \text{Pa}$ when its temperature is 10°C . What will be its pressure when its temperature is raised to 100°C and its volume doubled?

(2 marks)

.....

.....

.....

.....

.....

THIS IS THE LAST PRINTED PAGE

